

# THE STANDARD MODEL OF FUNDAMENTAL PARTICLES AND THEIR INTERACTIONS

RUN 7339

EVENT 1279

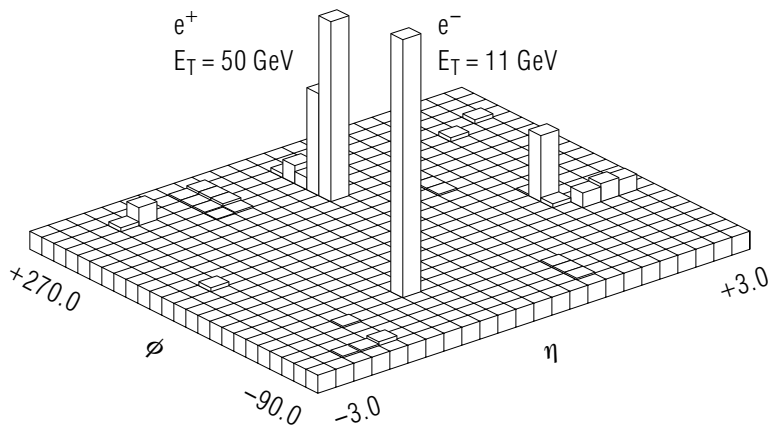

Project PHYSNET Physics Bldg. Michigan State University East Lansing, MI

## THE STANDARD MODEL OF FUNDAMENTAL PARTICLES AND THEIR INTERACTIONS

by  
Mesgun Sebbatu

<b>1. Overview</b> .....	1
<b>2. Historical Introduction</b>	
a. Gravity .....	2
b. Electromagnetism .....	2
c. The Weak “Nuclear” Force .....	3
d. The Strong “Nuclear” Force .....	4
<b>3. The Standard Model</b>	
a. Symmetry .....	5
b. Constituents and Mediators of the Standard Model .....	6
c. Weak Isospin and W Bosons .....	7
d. Electroweak Theory .....	7
e. Spontaneously Broken Symmetry—Phase Transition .....	8
f. Higgs Bosons .....	8
g. Relations Between Electroweak Theory Parameters .....	9
h. Experimental Detection of the W Boson .....	9
i. The Unification of QCD and Electroweak Theory .....	10
<b>Acknowledgments</b> .....	13

Title: **The Standard Model of Fundamental Particles and Their Interactions**

Author: Mesgun Sebhatsu, Department of Physics, Winthrop College, Rock Hill, SC 29733

Version: 11/14/2001

Evaluation: Stage 0

Length: 2 hr; 20 pages

**Input Skills:**

1. Using the quark model with four flavors and three colors, construct hadron multiplets. (MISN-0-283).

**Output Skills (Knowledge):**

- K1. State the major objective of physics and mention key events as well as physicists in history that contributed towards this goal.
- K2. Describe the four fundamental forces and compare their strength, range, and the masses of their gauge bosons.
- K3. Describe QED, QCD, and GSW theories and explain how they are unified by the standard model.
- K4. List fundamental fermions and gauge bosons of the standard model and give their generation number, mass, charge, and spin.
- K5. Describe how the W and Z gauge bosons are rendered massive.
- K6. Describe an experiment that supports the GSW theory.
- K7. List two major phenomena that the SSC may help uncover.

**Output Skills (Rule Application):**

- R1. Given any two of exchanged gauge boson mass, life time, and range for an interaction, estimate the third.
- R2. Given any two of W boson mass, Z boson mass, and Weinberg angle, calculate the third.
- R3. For any N, calculate the number of expected gauge bosons in an SU(N).
- R4. Given any two of the neutral ( $g'$ ) and charged ( $g$ ) electroweak coupling constants as well as the Weinberg mixing angle ( $\theta_W$ ), calculate the third.

THIS IS A DEVELOPMENTAL-STAGE PUBLICATION  
OF PROJECT PHYSNET

The goal of our project is to assist a network of educators and scientists in transferring physics from one person to another. We support manuscript processing and distribution, along with communication and information systems. We also work with employers to identify basic scientific skills as well as physics topics that are needed in science and technology. A number of our publications are aimed at assisting users in acquiring such skills.

Our publications are designed: (i) to be updated quickly in response to field tests and new scientific developments; (ii) to be used in both classroom and professional settings; (iii) to show the prerequisite dependencies existing among the various chunks of physics knowledge and skill, as a guide both to mental organization and to use of the materials; and (iv) to be adapted quickly to specific user needs ranging from single-skill instruction to complete custom textbooks.

New authors, reviewers and field testers are welcome.

PROJECT STAFF

Andrew Schnepf	Webmaster
Eugene Kales	Graphics
Peter Signell	Project Director

ADVISORY COMMITTEE

D. Alan Bromley	Yale University
E. Leonard Jossem	The Ohio State University
A. A. Strassenburg	S. U. N. Y., Stony Brook

Views expressed in a module are those of the module author(s) and are not necessarily those of other project participants.

© 2001, Peter Signell for Project PHYSNET, Physics-Astronomy Bldg., Mich. State Univ., E. Lansing, MI 48824; (517) 355-3784. For our liberal use policies see:

<http://www.physnet.org/home/modules/license.html>.

# THE STANDARD MODEL OF FUNDAMENTAL PARTICLES AND THEIR INTERACTIONS

by  
Mesgun Sebhatsu

## 1. Overview

In the last three decades, significant progress has been made in the identification of fundamental particles and the unification of their interactions. This remarkable result is summarized by what is now confidently called the Standard Model. This module presents a descriptive account of the Standard Model and its possible extensions. According to the Standard Model, all matter in the universe is made up of a dozen fermions—six quarks and six leptons. The quarks and leptons interact by exchanging a dozen gauge bosons—eight gluons and four electroweak bosons. The model provides a framework for the unification of the electroweak and strong “nuclear” forces. A major deficiency of the model is its lack of incorporation of gravity.

## 2. Historical Introduction

Our job in physics is to see things simply, to understand a great many complicated phenomena in a unified way, in terms of a few simple principles.—*Steven Weinberg*<sup>1</sup>

The development of the Standard Model of particle physics may be the best example for the major goal of physics—simplification and unification of seemingly diverse and complicated natural phenomena. The Standard Model can account for all atomic, nuclear, and subnuclear phenomena in terms of a dozen fermions and a dozen bosons. To appreciate the Standard Model, we need to start with a brief historical background of the four (three after 1967) fundamental forces—Gravity, Electromagnetism, the Weak Nuclear force and the Strong Nuclear force.

<sup>1</sup>S. Weinberg, *Rev. of Mod. Phys.*, “Conceptual Foundations of the Unified Theory of Weak and Electromagnetic Interactions” **52**, 515 (1980); *Science* **210**, 1212 (1980). I have quoted the first sentence of his Nobel lecture.

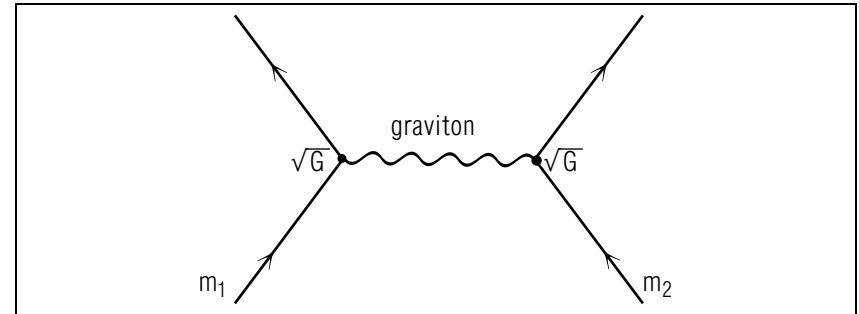

**Figure 1.** Second order Feynman diagram for gravitational interaction of two massive objects via graviton exchange.

**2a. Gravity.** The first fundamental force (interaction) to be defined accurately was gravity. This was accomplished by Isaac Newton in the seventeenth century when he stated his law of universal gravitation ( $F = Gm_1m_2/r^2$ ) in his *Principia*. Using his law, Newton was able to show that the force of gravity was responsible for motions of planets around the sun as well as for projectile motion on the earth’s surface. This was a revolutionary achievement since celestial and terrestrial motions were believed to be caused by different forces. His gravitational law was refined by Albert Einstein in 1916, almost three centuries later. According to Einstein’s general theory of relativity, gravity results from the curvature of space–time due to the presence of mass (or energy). There is now a concerted effort to develop the quantum theory of gravity. In the quantum theory formalism, the gravitational interaction is a consequence of the exchange of gravitons, which are massless particles with spin 2. Figure 1 represents a Feynman diagram that shows gravitational interaction as a consequence of graviton exchange. This is analogous to the case of weak interaction mediated by a W or Z boson.<sup>2</sup> The measure of strength in the gravitation case is Newton’s gravitational constant ( $G$ ) and in the case of the weak interaction Fermi’s coupling constant ( $G_F$ ). At each vertex of the diagrams the strengths are characterized by  $\sqrt{G}$  and  $\sqrt{G_F}$  for gravitational and weak interaction respectively.

**2b. Electromagnetism.** Prior to the eighteenth century, magnetic and electrical forces were regarded as unrelated entities. After Oersted, in 1819, discovered by accident that a current carrying wire deflected a magnetic compass needle, a series of experiments in the 1820’s by Faraday and Henry showed that a change in a magnetic field creates an electric

<sup>2</sup>See “The Weak Interaction” (MISN-0-281).

field. In addition, Ampère was able to conclude that electric current loops of atomic size were the basis for all magnetism. The intimate relationship between electric and magnetic forces culminated in the development of the electromagnetic theory by Clerk Maxwell in 1879. Maxwell's electromagnetic theory provided a complete unification of electricity and magnetism—electromagnetism. This is the first example of a unification of forces.

At any point in space a change in electric field (force per unit charge) is accompanied by a compensating change in the magnetic field at that point. This is characteristic of vector fields called gauge fields where local symmetry is preserved via compensating changes in various field components. A relativistic quantum version of electromagnetic theory was developed in the 1940's mainly by Feynman, Schwinger, and Tomonaga. It is called quantum electrodynamics or QED for short.<sup>3</sup> It is a theory unprecedented in its precise determination of observable quantities. Besides being the first example of unification of forces and a prototype gauge theory, electromagnetism is the interaction responsible for all atomic, molecular, and hence biochemical phenomena. In the language of quantum field theory, the electromagnetic interaction is mediated by a massless gauge (spin one) boson—the photon ( $\gamma$ ). The interaction can be represented by the second order (two vertices) Feynman diagram.<sup>4</sup>

**2c. The Weak “Nuclear” Force.** Weak interactions are responsible for radioactivity such as  $\beta$  decay. In 1930 Pauli postulated that a massless spin one-half particle called the neutrino must accompany the emission of the  $\beta$  particle by a neutron if energy, momentum, and spin statistics are to be conserved. Four years later, Fermi developed the first quantum theory of the weak interaction. This is known in the literature as the four-fermion interaction. The interaction is represented by a product of four fields at a single vertex.<sup>5</sup> The coupling strength of the four fields is Fermi's constant ( $G_F$ ).

According to Heisenberg's uncertainty principle, a point interaction implies the exchange of a particle of infinite mass. This was considered unrealistic and was later remedied by Klein (1938) who introduced heavy quanta of spin one, now known as  $W^\pm$  and  $Z$  bosons. Fermi's theory is still valid for interaction energies below the  $W$  and  $Z$  boson masses. That

<sup>3</sup>Particle physics is governed by a theory that combines relativity and quantum theory called quantum field theory. QED is a quantum field theory that deals with electromagnetism.

<sup>4</sup>See “Strengths of Interactions and Particle Diagrams” (MISN-0-279).

<sup>5</sup>See “The Weak Interaction” (MISN-0-281).

is, up to about 100 GeV.

**2d. The Strong “Nuclear” Force.** The strong force is responsible for binding nuclei. A direct means of studying the force is to study the interaction between two nucleons. The neutron was discovered in 1932. This meant that the nucleus is made up of protons and neutrons, together nucleons. Using the then-known forces, primarily the electromagnetic force, it was impossible to account for the stability of nuclei. The electromagnetic force would, in fact, push protons violently apart. This paved the way for Yukawa (1935) to suggest a short-range strong nuclear force.

A short-range force requires the exchange of a massive particle. Yukawa, therefore, predicted the mediator of the strong nuclear force, the pion, with a mass of approximately 140 MeV. It follows from the uncertainty principle ( $\Delta t \Delta E \geq \hbar$ ) that the range of the strong nuclear force ( $R \simeq c \Delta t \simeq \hbar / m_\pi c$ ) is  $1.4 \times 10^{-15}$  m.<sup>6</sup>

Besides the pion, many other mesons have been discovered and continue to be discovered. The Yukawa approach has been used to develop two-nucleon interaction models by utilizing various mesons. Even though the approach is useful at low energy, it is now believed that meson-exchange forces are a manifestation of a more fundamental force called the strong color force. In analogy with quantum electrodynamics, a theory of strong interactions based on quarks and color exchange called quantum chromodynamics has been developed. Just as quantum electrodynamics is QED, quantum chromodynamics is abbreviated QCD.

### 3. The Standard Model

The Standard Model unifies the strong force of QCD and the electroweak force which results from the unification of QED and weak interaction theory. A quantitative description of the Standard Model can involve quantum field theory, group theory, and evaluation of complicated integrals related to Feynman diagrams. Our objective in this module is to give a descriptive account of the development of the Standard Model with emphasis on the unification framework it provides at the moment and the directions it may lead for future theoretical extensions and experimental tests.

<sup>6</sup>For calculation details and pion-exchange Feynman diagrams related to the strong interaction, see “The Strong Interactions” (MISN-0-280).

**3a. Symmetry.** Symmetry plays a central, unifying, and simplifying role in physics. Symmetry implies invariance. All the conservation laws of physics are principles of invariance. For example, translational and rotational invariance lead to the conservation of linear and angular momentum, respectively. Symmetry, such as that related to rotational and translational invariance, is expressed by a set of transformation rules that constitute a mathematical group. These groups can also describe transformations of internal symmetries such as the interchange color and flavor of quarks. For example, “Special Unitary” groups of dimension three,  $SU(3)$ , were used to describe the symmetry based on three-quark flavors as well as three-quark colors.<sup>7</sup> Similarly,  $SU(2)$  can be used to describe isospin doublets that interact via weak interaction. The simplest group is a one-dimensional unitary group called  $U(1)$ . It is the symmetry associated with QED. It involves one gauge boson—the photon ( $\gamma$ ) and a conserved quantity—the total charge ( $Q$ ).  $U(1)$  is analogous to the symmetry exhibited by a circle rotating on an axis perpendicular to its center. In the language of group theory, the product  $SU(3) \times SU(2) \times U(1)$ , represents the underlying symmetry of the Standard Model. This is equivalent to saying the Standard model incorporates the symmetries representing the electroweak theory ( $SU(2) \times U(1)$ ) and QCD ( $SU(3)$ ).

<sup>7</sup>See “ $SU(3)$  and the Quark Model (MISN-0-282)” and “Color and Charm” (MISN-0-283).

Constituent Particles of the Standard Model				
Table 1. Quarks and Leptons come in three generations of doublets. Each quark has three possible colors red (R), blue (B), green (G). The leptons are colorless. For each quark and lepton there is a corresponding antiquark and antilepton. The quark masses given correspond to approximate rest mass energy of quarks confined in hadrons. For example, the uor dquark mass is one-third that of the nucleon mass and the c quark mass is one-half of the $J/\psi$ meson mass. (Masses as low as 4 MeV and 7 MeV for the uand dquarks respectively are given by some authors.) Since free quarks have not been observed, quark mass estimates are somewhat uncertain.				
Generation	Quarks		Leptons	
First Mass	u (up) 330 MeV	d (down) 333 MeV	e (electron) 0.511 MeV	$\nu_e$ < 15 eV
Second Mass	c (charmed) 1.5 GeV	s (strange) 550 MeV	$\mu$ (muon) 107 MeV	$\nu_\mu$ < 0.6 MeV
Third Mass	t (top) > 100 GeV	b (bottom) 5 GeV	$\tau$ (tau) 1784 MeV	$\nu_\tau$ < 250 MeV
Charge	+2e/3	-e/3	-e	0
Color	R G B	R G B	colorless	colorless

**3b. Constituents and Mediators of the Standard Model.** According to the Standard Model, all matter in the universe is made up of a dozen fermions (and their antiparticles)—six quarks (u, d, s, c, t, b) and six leptons (e,  $\nu_e$ ,  $\mu$ ,  $\nu_\mu$ ,  $\tau$ ,  $\nu_\tau$ ) that come paired up as doublets of three generations. For each quark flavor there are three colors.<sup>8</sup> All the quarks and lepton are fermions. That is, they have spin one-half. Particles with integral spin are called bosons. In particular, those with spin 1 are called gauge bosons and those with spin 0 are called scalars. The Standard Model requires the  $W^+$ ,  $W^-$ , Z, and  $\gamma$  spin-one gauge bosons to mediate the electroweak force and eight gluons to mediated the strong or color force.<sup>9</sup> The constituent particles of the Standard Model and some of their properties are listed in Table 1. The gauge bosons and the forces they mediate are listed in Table 2. Gravity is included for completeness even though it is not part of the Standard Model.

<sup>8</sup>In this module, the primary colors red, green and blue (RGB) are used. Some authors, prefer yellow to green. The physics is not affected by this. However, most authors use the primary colors.

<sup>9</sup>For a discussion of gluons, see “Color and Charm” (MISN-0-283).

Comparison of Fundamental Forces					
Table 2. A comparison of the range, relative strength, and some properties of mediators of the fundamental forces. All the given values, except spin, are approximate. $Gm_p^2$ represent the gravitational strength. $G$ is the Newtonian constant and $m_p$ is the proton mass. $\alpha \simeq 1/137$ characterizes the electromagnetic strength. $G_F m_p^2$ , the product of four-fermion coupling and square of the proton mass is a measure of the weak force strength. $\alpha_s \simeq 1$ is the color force strength.					
Force	Range	Strength	Boson	Mass (GeV)	Spin
Gravity	$\infty$	$10^{-38}$	graviton	0	2
E. M.	$\infty$	$10^{-2}$	photon	0	1
Weak	$< 10^{-18}$ m	$10^{-5}$	$W^\pm, Z^0$	80, 90	1
Strong	$< 10^{-15}$ m	1	gluons	0	1

**3c. Weak Isospin and W Bosons.** The grouping of quarks and leptons into pairs of three generations suggests that the quarks and leptons of each generation are weak isospin doublets in analogy with the fact that the proton and neutron are isospin doublets that are indistinguishable by the strong force. An isospin group with two members satisfies a symmetry representation called SU(2). In general we can have SU(N) for N-particle multiplets or properties. For any SU(N) with N>1 there are N<sup>2</sup>-1 gauge bosons. Consequently, for the weakly interacting weak isospin group SU(2), there must be three gauge bosons. Tentatively these can be identified as the weak isovector triplet:  $W^+$ ,  $W^-$ , and  $W^0$  bosons.

**3d. Electroweak Theory.** In the 1960's Glashow, Salam, and Weinberg were able to unify the weak interaction with the electromagnetic interaction by combining the SU(2) weak isospin group with the U(1) singlet that represents QED. The product SU(2)×U(1) leads to electroweak theory.

The developers of the electroweak theory, Sheldon Glashow, Abdus Salam, and Steven Weinberg, were awarded a Nobel prize in 1979, exactly a century after the unification of electricity and magnetism by Maxwell. The electroweak theory they developed predicted the masses of the  $W^\pm$ , and  $Z^0$  bosons to be about 80 GeV and 90 GeV respectively.<sup>10</sup> In 1983, physicists at CERN (an European Organization for Nuclear Research) led by Carlo Rubia were able to produce and measure the masses of the W and Z bosons. The measured masses were in complete agreement with

<sup>10</sup> See for example, Abdus Salam, "Gauge Unification of Fundamental Forces", *Rev. of Mod. Phys.* **52**, 531 (1980); *Science* **210**, 723 (1980). He gives the range of values  $M_W \simeq 77$  to 84 GeV and  $M_Z \simeq 89$  to 95 GeV.

the predictions of the electroweak theory. The fact that the electroweak theory was recognized by a Nobel prize before the W and Z bosons were discovered demonstrates the confidence the physics community had for it.

**3e. Spontaneously Broken Symmetry—Phase Transition.** If the electroweak theory based on SU(2)×U(1) is to have perfect symmetry, the electroweak isospin triplets—the W bosons and the electroweak singlet—the photon, must have equal mass. Since the photon has zero mass, this meant the W bosons would be required to have zero masses as well. However, it was clear from the outset that the weak interaction has an extremely short-range  $R \simeq 10^{-18}$  m. This implies masses of W that is of the order of 100 GeV.

As it stands, the SU(2)×U(1) symmetry is very far from perfect. It involves gauge boson such as the W and Z bosons that have mass of the order of 100 GeV and the photon which is massless. This asymmetry requires some justification. The developers of the electroweak theory start with four massless gauge bosons. The triplets  $W^+$ ,  $W^-$ ,  $W^0$  and a  $B^0$ , an isospin singlet. This would provide a perfect symmetry at very high energy (at  $E \geq 100$  GeV) or equivalently at very high temperatures ( $10^{15}$  K). At lower energies or temperatures, a phase transition occurs and the symmetry is broken (lost or hidden). As a result of the spontaneously broken symmetry, the  $W^\pm$  obtain mass and the  $W^0$  and  $B^0$  mix and yield the massive  $Z^0$  boson and the massless photon ( $\gamma$ ).

Familiar examples of spontaneously broken symmetry are the phase transition that occurs when water freezes to ice below 0° C and when a red hot bar-shaped ferromagnet regains its magnetism after it is cooled. Water exhibits more symmetry than ice and the hot iron bar magnet has no polarity and hence no preferred orientation in space: the loss of its magnetism makes it symmetrical. These two relatively familiar examples require exchange of thermal energy with their environment to undergo phase transition. One can thus ask what environmental factors affect the gauge boson of the electroweak force.

**3f. Higgs Bosons.** It is believed that the W and Z bosons obtain their mass from Higgs scalar bosons (suggested by Peter Higgs in 1963). At the energy ranges where perfect SU(2)×U(1) is prevalent a Higgs isospin doublet ( $H^+$ ,  $H^0$ ) and its antiparticles ( $H^-$ ,  $\bar{H}^0$ ) are supposed to exist. The Higgs scalar bosons generate mass due to their mutual self interaction. When a phase transition or spontaneous symmetry breaking occurs the masses generated by the  $H^\pm$  pair is absorbed by the  $W^\pm$  bosons and part of the mass from the  $H^0$ - $\bar{H}^0$  pair is used by the  $Z^0$  boson. Since the

photon emerges massless, sufficient mass is available for a free  $H^0$  boson. A massive neutral Higgs boson ( $H^0$ ) should, therefore, be available for observation in supercolliders such as the Superconducting Super Collider, the SSC.<sup>11</sup> The search for the neutral Higgs boson is likely to be difficult. Unlike the W and Z bosons its mass is not constrained by theory.

**3g. Relations Between Electroweak Theory Parameters.** An important parameter introduced by the mixing of the  $W^0$  and  $B^0$  bosons is the  $\theta_W$ , the Weinberg mixing angle. This angle relates the masses of the W and Z bosons as well as the electromagnetic ( $e$ ), charged weak ( $g$ ), and neutral weak ( $g'$ ) couplings. Here is a summary of these important relations:<sup>12</sup> (we use the so-called “natural units” of particle physics,  $c = \hbar = 1$ )

$$\begin{aligned} e^2 &= g^2 \sin^2 \theta_W, \\ \alpha &= \frac{e^2}{4\pi} \simeq \frac{1}{137} \\ M_{W^\pm} &= \left[ \frac{\pi\alpha}{\sqrt{2}G_F \sin^2 \theta_W} \right]^{1/2} = \frac{37.3 \text{ GeV}}{\sin \theta_W} \\ M_{Z^0} &= \frac{M_{W^\pm}}{\cos \theta_W} \\ 1 + \frac{g'^2}{g^2} &= \frac{1}{\cos^2 \theta_W}. \end{aligned}$$

The constant 37.3 GeV above is related to the known values of electron charge and the four-fermion coupling constant ( $G_F \simeq 1.166 \times 10^{-5} \text{ GeV}^{-2}$ ). A current experimental value for the Weinberg mixing angle ( $\theta_W$ ) is about  $28^\circ$  ( $\sin^2 \theta_W \simeq 0.22$ ). Using the above relations one can estimate the  $M_{W^\pm}$  and the  $M_{Z^0}$  to be about 80 GeV and 90 GeV respectively. As shown in the above equations, the predictions are sensitive to the mixing angle value.

**3h. Experimental Detection of the W Boson.** Two international groups<sup>13</sup> of physicists totalling about 200 detected the W boson in January 1983 at CERN in Europe. A few months later, the same group(s)

<sup>11</sup>The SSC, which was to have been built in Texas, was expected to attain 20 TeV (20,000 GeV) of beam energy. For details see J.D. Jackson et al. *Sci. American*, March 1986.

<sup>12</sup>For derivations and detailed list of references, see e.g. H. Frauenfelder and E. M. Henley, *Subatomic Physics*, 2<sup>nd</sup> ed. (1991).

<sup>13</sup>Known in the literature as UA1 and UA2—underground collaboration A1 and A2 respectively.

discovered the Z boson as well. It was impressive that the masses of these bosons were as predicted by the GSW theory. The leaders of these groups—Carlo Rubia and Simon van der Meer—received a Nobel prize in 1984 for their remarkable achievement. Their work involved the modification of a Super Proton Synchrotron (SpS) at CERN to make a Super Proton Antiproton Synchrotron (Sp $\bar{p}$ S).<sup>14</sup> The Sp $\bar{p}$ S enabled them to conduct a  $p\bar{p}$  head on collision with energies of about 270 GeV per beam. That is, a total of 540 GeV per collision. This provides sufficient energy for the  $W^\pm$  and  $Z^0$  to be produced in the reactions:

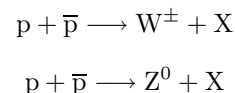

The W and Z produced by the above reactions immediately decay:

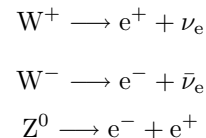

The lifetime of the W and Z bosons is about  $10^{-24}$  seconds. The  $W^\pm$  can decay into  $e^+\nu_e$  or  $e^-\bar{\nu}_e$  and the  $Z^0$  into  $e^-e^+$  pairs. The decay products fly away opposite to each other (conservation of momentum dictates this) in a direction that is transverse to the beam directions while the fragments ( $X = \dots$ ) disperse in the beam directions. The masses of the W and Z bosons can be calculated from the momentum and energy of the decay products shown in Fig. 2. Figure 3 shows a “lego” plot of the energy deposited in a detector when a  $Z^0$  boson decays in to an electron ( $e^-$ ) and a positron ( $e^+$ ) pair.

**3i. The Unification of QCD and Electroweak Theory.** The Standard Model is a result of the combination of the electroweak theory (GSW theory) with quantum chromodynamics (QCD). Both QCD and the GSW theory enjoy experimental support. They also have some predictions that have not yet been realized.

The discovery of the W and Z bosons is a very strong confirmation of the electroweak theory. In addition, the GSW theory predicts a free neutral Higgs scalar meson that still have not been seen. The Superconducting

<sup>14</sup>For details, see D. B. Cline, Carlo Rubia and S. van der Meer, *Sci. American*, March 1982. See also the Nobel lectures by C. Rubia and S. van der Meer, *Rev. of Mod. Phys.* **57**, 689 and 699 (1985).

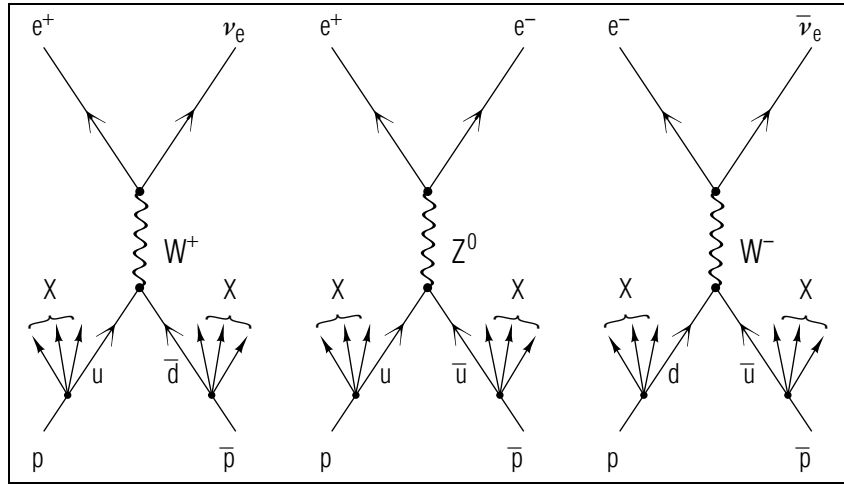

**Figure 2.** Second order  $p\bar{p}$  collision Feynman diagrams for the production of W and Z bosons and their decay products.

Super Collider (SSC) should intensify the search for the Higgs scalar boson. So far the GSW theory is consistent with all available electroweak

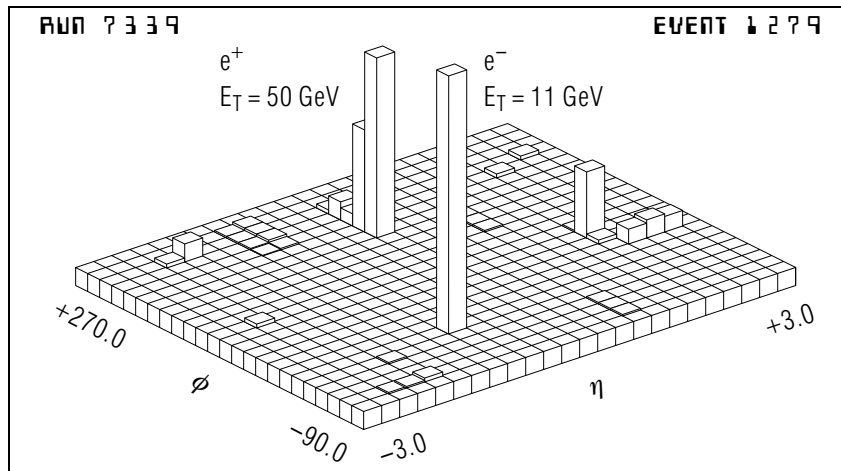

**Figure 3.** Energy deposited by the decay of  $Z^0$  into an electron ( $e^-$ ) and a positron ( $e^+$ ) pair after a  $p\bar{p}$  collision.  $\phi$  and  $\eta$  are angles in the detector. Adopted from: G. Arnison et al. (UA1 collaboration), Phys. Lett. **126B** 398 (1983).

data. A discovery of the Higgs boson will just be the final touch it needs to be completely on firm ground.

In parallel with the GSW theory, there have been developments in quantum chromodynamics (QCD). There is now evidence for five quark flavors. The sixth quark is being searched for.<sup>15</sup> The six flavors of quark come in three generations of weak isospin doublets that lead to SU(2) symmetry. Each quark has three possible colors. The fact that quarks come in three colors is used as the basis for SU(3) symmetry. The SU(3) color symmetry is exact since the three colored quarks of each flavor are identical in every respect except color. The SU(3) symmetry of colored quarks would automatically require eight ( $3^2 - 1 = 8$ ) gauge bosons. These are the eight gluons made up of color-anticolor quark pairs. The construction of gluons is identical to the that used to obtain meson multiplets using quark-antiquark pairs. The gluons are responsible for mediating the strong color force that binds hadrons.

The Standard Model results when the electroweak theory group represented by  $SU(2) \times U(1)$  is extended to include the SU(3) colored quark group which represents QCD. The Standard Model can account for all hadronic (strong interaction) and electroweak phenomena. Meson exchange effects that are still useful in describing low energy nuclear phenomena are residual effects of the strong color force in the same way that molecular forces are consequences of the electromagnetic force. The only fundamental force missing in the picture portrayed by the Standard Model is the gravitational force. Once the model is extended to include gravity, it will be possible, at least in principle, to explain all phenomena in the universe as a consequence of a single fundamental interaction. That is, one will have a Theory of Everything (TOE).

Development of Theories of Every Thing (TOEs) is an active research frontier that is being pursued by high energy theoretical physicists. A current contender for TOE is the highly speculative and, consequently, controversial theory called "Superstring Theory."

<sup>15</sup>There is a good chance that evidence for the sixth quark (top quark) may be available in any of the colliders operating with energies of the order of 1 TeV and higher. For example, at Fermi Lab. The SSC would have helped settle the issue as to whether generations of quarks and leptons exist beyond the third.



## Acknowledgments

The author is grateful to Michigan State University for awarding him a Martin Luther King, Jr.—Cesar Chavez—Rosa Parks Visiting Professorship and to Winthrop College for granting him a sabbatical leave for the 1991-92 academic year. He would also like to thank Professor Peter Signell for his kind hospitality and for encouraging him to participate in the PHYSNET project. Preparation of this module was supported in part by the National Science Foundation, Division of Science Education Development and Research, through Grant #SED 74-20088 to Michigan State University.

## PROBLEM SUPPLEMENT

### Advice:

The electroweak theory developed by Glashow, Salam, and Weinberg relates the electroweak coupling constants— $e$ ,  $g$ ,  $g'$  and the masses  $M_W$  and  $M_Z$ . An important parameter in relating (or mixing) the coupling constants and masses is the Weinberg mixing angle ( $\theta_W$ ). The boson masses have the simple relation  $M_W = M_Z \cos \theta_W$ . A simple way to remember the relations between the coupling constants is with the aid of this right-angle triangle:<sup>16</sup>

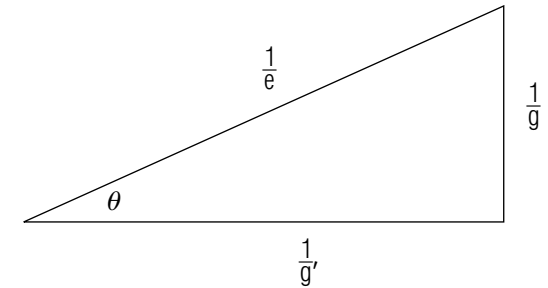

From the above triangle it follows that:  $e = g \sin \theta_W = g' \cos \theta_W$ . Using the pythagorean theorem it is clear that

$$\frac{1}{e^2} = \frac{1}{g^2} + \frac{1}{g'^2}.$$

For convenience  $e$  can be defined as a dimensionless quantity using  $e^2/(4\pi) \simeq (1/137)$ .

1. Show that  $e \simeq 0.303$ ,  $g \simeq 0.646$ , and  $g' \simeq 0.343$  are consistent with  $\theta_W \simeq 28^\circ$ .
2. In the relation

$$M_W = \sqrt{\frac{\pi\alpha}{\sqrt{2}G_F \sin^2 \theta_W}} = \frac{37.3 \text{ GeV}}{\sin \theta_W},$$

calculate the constant 37.3 GeV ( $G_F \simeq 1.166 \times 10^{-5} \text{ GeV}^{-2}$  and  $\alpha \simeq (1/137)$ ).

3. If the value of  $\sin^2 \theta_W$  ranges from 0.219 to 0.229 in the literature, calculate the corresponding ranges for the masses  $M_W$  and  $M_Z$ .

<sup>16</sup>R. K. Adair, *The Great Design*, Oxford U. Press (1987), p. 337

**MODEL EXAM**

Speed of light:  $c = 3 \times 10^8$  m/s;  $\hbar c = 197.3 \times 10^{-18}$  GeV m  
Give mass in  $\text{GeV}/c^2$ , energy in GeV, time in seconds, distance in meters

1. See Output Skills K1-K7 in this module's *ID Sheet*.
2. Using a Weinberg angle of  $28^\circ$  estimate the mass of the Wand Zbosons.
3. A proton and a neutron constitute an SU(2) multiplet. Calculate the the number of force carriers (bosons) expected from the SU(2) symmetry.
4. The range of the electromagnetic and gravitational forces are infinite. What are the masses of the gauge bosons that mediate these forces?
5. If the charged coupling constant,  $g \simeq 0.343$  and  $\sin^2 \theta_W \simeq 0.22$ , calculate the neutral coupling constant ( $g'$ ).
6. The long range part of the strong nuclear force is due to the exchange of a pion between two nucleons. The pions have a mass of about  $140 \text{ MeV}/c^2$ . Using Heisenberg's uncertainty principle, estimate the range of the strong nuclear force.